

Electrical systems - Electronic modules - Electronic module - Universal controller - H1 - Calibration procedures

The Universal controller (U1) is used to calibrate the following components:

- Front PTO
- EDC
- Steering Sensor
- Front Suspension
- Rear EHR
- Front Hitch
- Advanced Steering (AST)

NOTE: In this menu, tractor driveability is allowed.

H1 Menu Screen Select Diagram

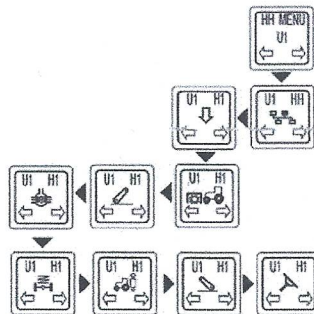

MOIL19TR01190AA 2

HH Menu Entry

Install the diagnostic connector **380000843** into the diagnostic socket.

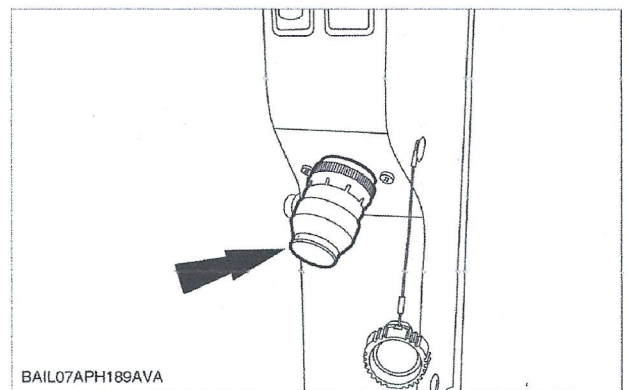

BAIL07APH189AVA

BAIL07APH189AVA 3

Use the "h" "m" and "dimming" buttons on the instrument cluster to navigate the HH menus to H1 and the transmission symbol on the U1 controller.

Connector - Component diagram 03

X030 Diagnostics Plug - CAN BUS 1

POS.	COLOR	WIRE NUMBER	CIRCUIT REFERENCE
A	BK	57	EARTH (ALL)
B	GN	6408	FUSED B+ TO ECU (1)
C	YE	5400	CAN H
D	GN	5420	CAN L
E	PK	6418	ECU TO J1941(ISO) INTERFACE #2 CONNECTOR ISO K
G	GN	2200	SERVICE MODE INITIATE
H	YE	5910	ISO BUS CAN SIGNAL HIGH
J	GN	5900	ISO BUS CAN SIGNAL LOW

NOTE: For the wiring color code refer to, *Wiring harness - Identification (A.30.A)*.

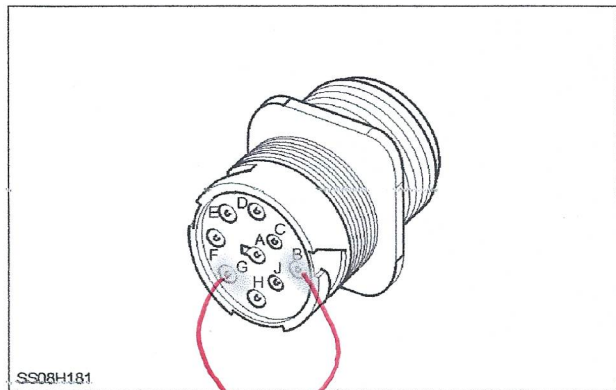
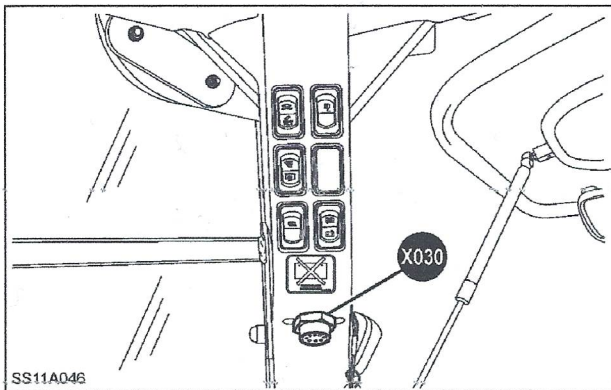

CAB RIGHT HAND C-PILLAR

* Loop G → B
 then turn key ON for
~~the~~ H menu

Advanced Steering (AST) Calibration

Both the Wheel Angle Sensor (WAS) and the electro-hydraulic spool need to be calibrated. The WAS calibration and the spool calibration have to be performed in sequence because the spool calibration is only allowed once the WAS calibration has been successfully completed.

NOTE: The calibration procedure is controlled by the electronic management system. To prevent inadvertent movement of the tractor, firmly apply the parking brake and block the wheels, front and rear. Check that the ground speed display is zero before commencing. Calibration cannot proceed unless the tractor is stationary.

Set the engine speed to **1300 RPM** and verify that the oil temperature is above **5 °C**. Cycle the Field/Road switch to Field if in Road or to Road and then Field if already in Field (calibration needs for a transition from Road to Field being detected).
 Apply the park brake.

The user can access the calibration interface entering the HH menu (for both WAS and Spool calibration) or keeping the "AG engage" rocker switch pressed at key-on (shortcut for WAS calibration only).

HH Menu Entry

Install the diagnostic connector **380000843** into the diagnostic socket.

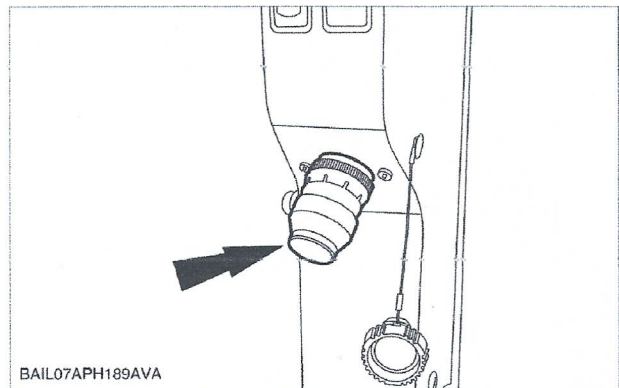

BAIL07APH189AVA

BAIL07APH189AVA 80

Start the engine.

Use the "h", "m" and "dimming" buttons on the instrument cluster to navigate the HH menus to H1 and the AST symbol on the U1 controller.

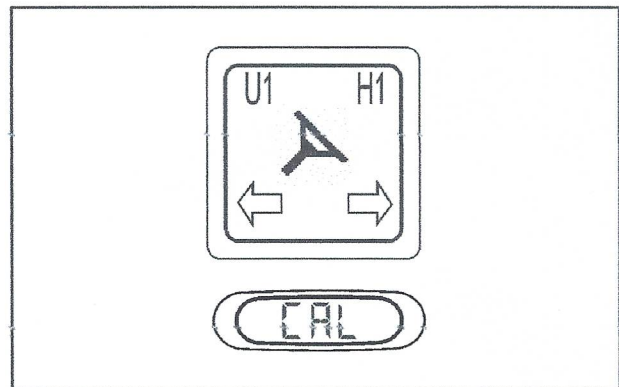

SVIL17TR04103AA 81

Use the "h" and "m" buttons to toggle between the available options:

- "vvas" - wheel angle position sensor (WAS)
- "SPool" - electro-hydraulic spool

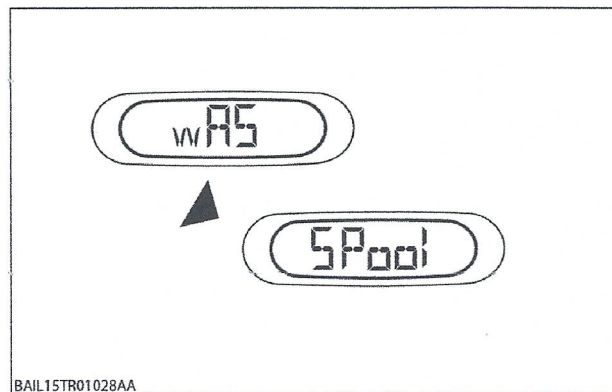

BAIL15TR01028AA

WAS calibration

NOTICE: Make sure that the following calibration is carried out in a wide area in order to achieve full steering angles in both directions.

Select the "vvas" option by depressing the "dimming" button and press the AutoGuidance engage switch on the hand controller to confirm.

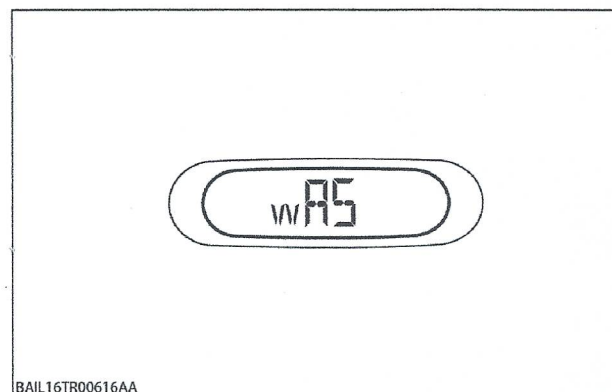

BAIL16TR00616AA

The right ("RGHT"), left ("LEFT") and neutral ("ntrl") positions are available to be calibrated in this sequence as follows:

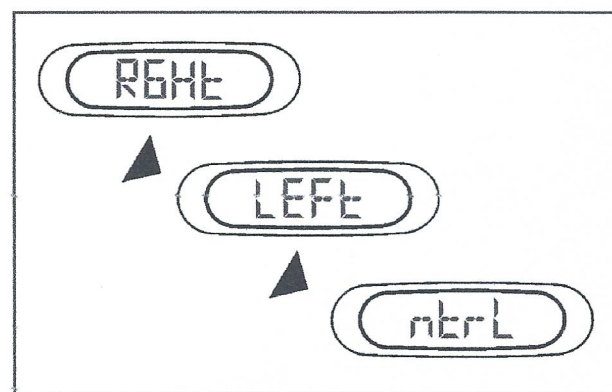

The lower central display will show "RGHT".

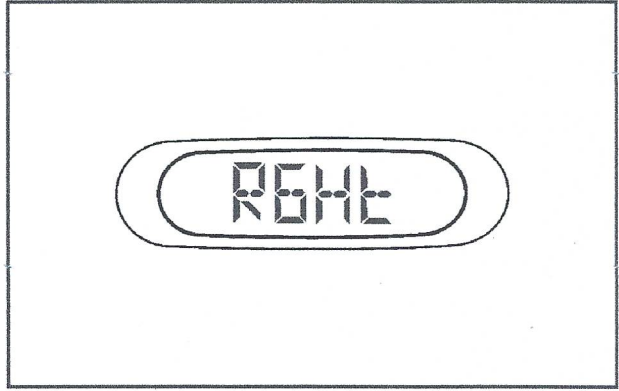

SVIL17TR04105AA 89

Steer completely to the right end position and press the AutoGuidance engage switch on the MFH to calibrate the "right end position" of the wheels. When the values are stored into the module, "PASS" is displayed in the lower central display. Press the AutoGuidance engage switch on the MFH to confirm the calibration.

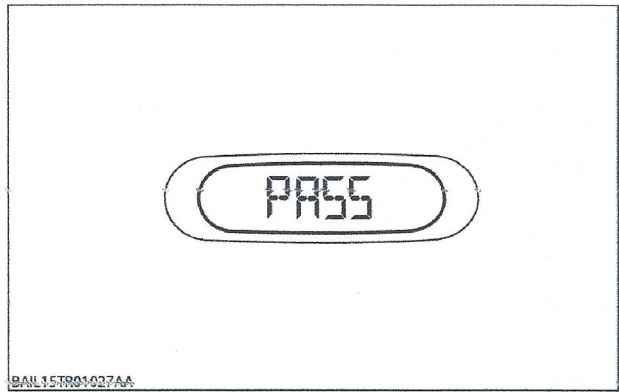

BAIL15TR01027AA

BAIL15TR01027AA 91

The lower central display will show "LEFT".

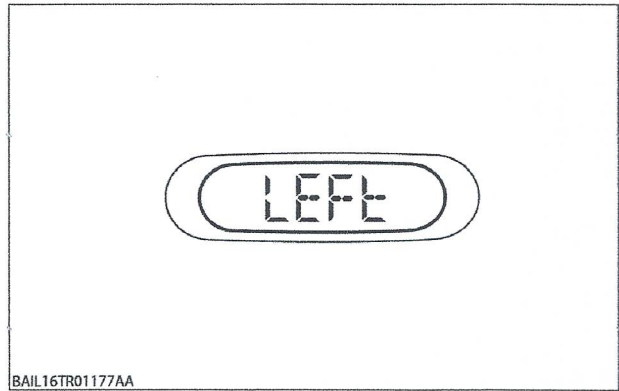

BAIL16TR01177AA

BAIL16TR01177AA 93

Steer completely to the left end position and press the AutoGuidance engage switch on the MFH to calibrate the "left end position" of the wheels. When the values are stored into the module, "PASS" is displayed in the lower central display. Press the AutoGuidance engage switch on the MFH to confirm the calibration.

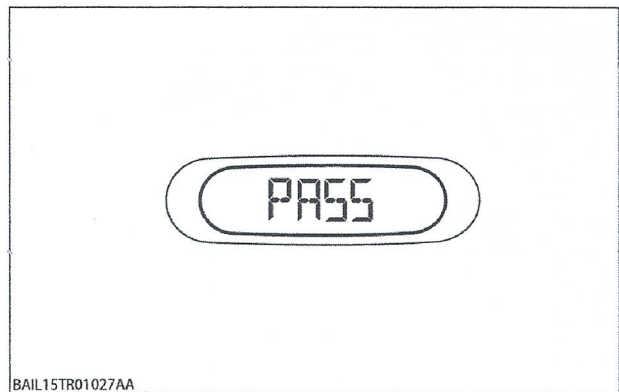

BAIL15TR01027AA

BAIL15TR01027AA 95

The lower central display will show “ntrl”.

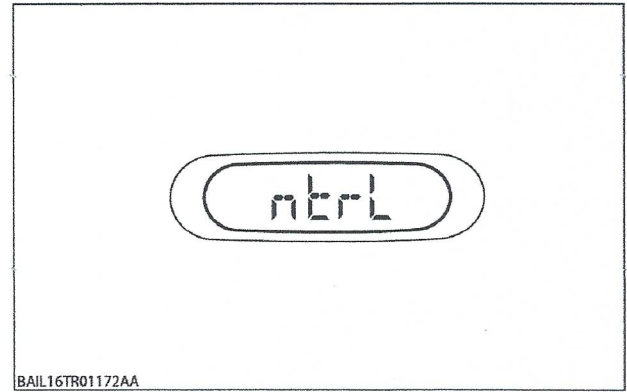

BAIL16TR01172AA

BAIL16TR01172AA 97

Steer in the straight ahead position and press the Auto-Guidance engage switch on the MFH to calibrate the “straight ahead position” of the wheels. When the values are stored into the module, “PASS” is displayed in the lower central display. Press the AutoGuidance engage switch on the MFH to confirm the calibration.

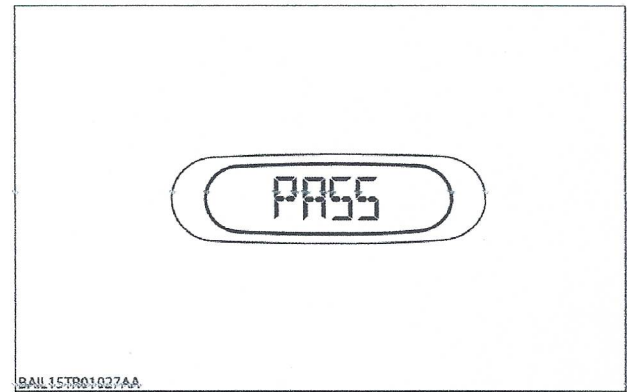

BAIL15TR01027AA

BAIL15TR01027AA 99

If procedure has been performed correctly via shortcut, “End” will be displayed in the lower central display.

NOTE: The WAS calibration is allowed also while moving, at reduced speed, the tractor.

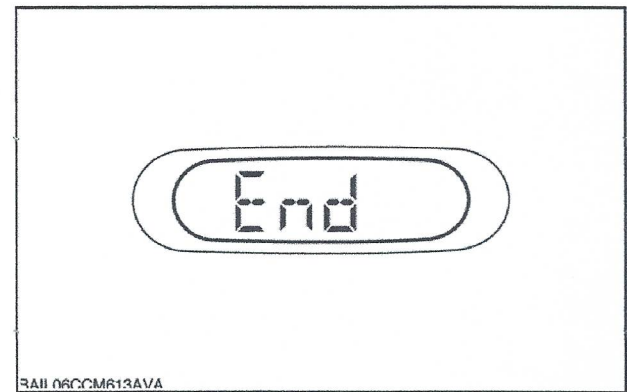

BAIL06CCM613AVA

BAIL06CCM613AVA 101

If procedure has been performed via HH menu, Spool calibration will start (point below). Otherwise, the procedure is aborted (operator needs to restart it) and a U-code will be displayed, refer to the Steering calibration 'U' error codes table.

NOTE: The WAS calibration is allowed also while moving, at reduced speed, the tractor.

NOTE: To be sure that the calibration has been performed correctly, turn the wheels completely to the right and the left. If the fault code 15327 appears, the calibration has not been performed correctly. Perform it again and be careful to turn the wheel completely. If the calibration has been started via HH menu, perform this check after completing the spool calibration. To calibrate the spool

Spool calibration

NOTE: To carry out the Spool calibration it is necessary to carry out the WAS calibration first.

Set engine speed above **1300 RPM** and apply the park brake.

Select the "SPool" option by depressing the "dimming" button and press the AutoGuidance engage switch on the MFH to confirm.

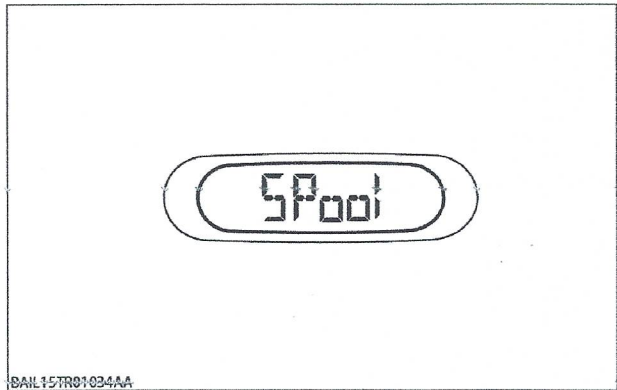

BAIL15TR01034AA

BAIL15TR01034AA 103

The SPool calibration cannot start until "MOVE" is displayed in the lower central display.

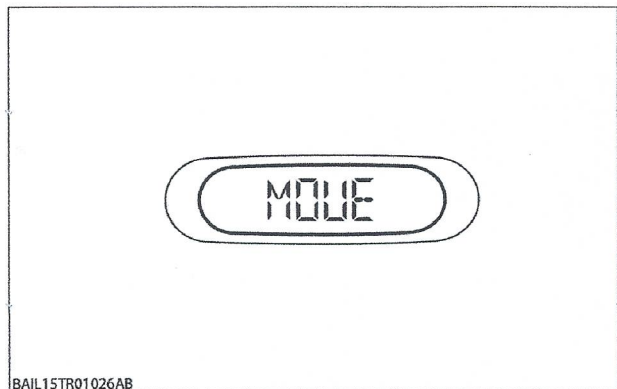

BAIL15TR01026AB

BAIL15TR01026AB 105

Move the steering wheel. After pressing the autoguidance engage switch, display shows "ALgn" in the lower central display if the steering is not aligned or "ntrl" if the wheels are in the neutral position (in this latter case, moving the steering wheel or putting it in a position different from neutral or not pressing the autoguidance engage button within **10 s** can cause a restart of the calibration to "MoVe" instruction). Pressing again the autoguidance engage switch when the display shows "ALin": in this way, the automatic spool calibration can start and proceed automatically

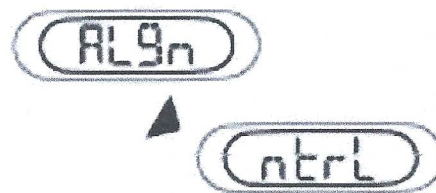

MOIL19TR01191AA 107

If the procedure has been carried out correctly, "End" will be displayed on the instrument cluster.
 If the procedure is aborted an U-code will be displayed, refer to the Steering calibration 'U' error codes table.

NOTE: The spool calibration is allowed to start only if the handbrake has been applied, otherwise the code U20 will be shown on the instrument cluster.

NOTE: The spool calibration requires the road/field mode switch set in "field mode" position.

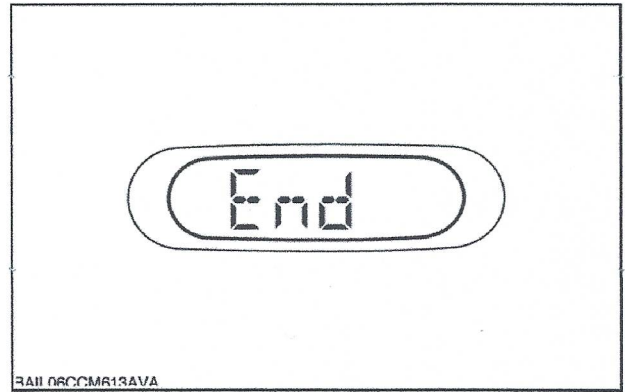

BAIL06CCM613AVA 109

After a short delay the display will return to the "H1" menu display.

NOTE: Err The procedure has been aborted due to an unspecified error. Try again.

Calibration 'U'-codes

Code	Description	Possible failure
U19	Oil temperature below 5 °C	1) Open circuit for the temperature sensor input to the transmission module 2) Faulty temperature sensor NOTE: Use the H9 menu in the U1 module to see if the temperature sensor input is OK, see Electronic module Universal controller - H9 - Voltmeter diagnostic (55.640.AG.12-F.90.B.18) NOTE: This U-code shall be raised only during spool calibration.
U20	Handbrake is not applied	1) Open circuit for the handbrake feed into the transmission module 2) Faulty handbrake switch 3) Switched 12 V supply fuse blown NOTE: Use the H5 switch diagnostics to detect if the handbrake is connected.
U21	ERPM is below 1300, increase throttle	1) Operator has not set the correct engine speed. 2) Open circuit for the engine speed sensor going to the cluster – mechanical engines only. 3) Instrument cluster is not powered. 4) Broken CAN bus.
U185	Necessary input signal not available	1) Wiring problem 2) Inputs damaged
U186	Calibration error due to fault consistency check or any other unknown failure	1) Wheel angle position out of range on WAS calibration. 2) PVED-CLS input consistency check failed. 3) PVED-CLS input not available. PVED-CLS input not consistent.
U187	Parameter update failed	1) PVED-CLS internal failure.
U188	Value out of range or invalid wheels angle position	1) Incorrect position for wheels (not in central position) 2) Faulty sensors
U189	Steering wheel movement observed	1) Faulty fast steer hydraulic valve 2) Incorrect assembly of hydraulic valve

Code	Description	Possible failure
U219	AST field/road switch is not in field position	1) Roding switch is in 'On-road' position 2) Harness failure 3) Possible CAN communication error between steering controller and vehicle controller
U255	Autoguidance engage button error	1) Autoguidance engage button (on ACML) not available. 2) Faulty autoguidance engage button