

Wheel Angle Sensor Kit Installation

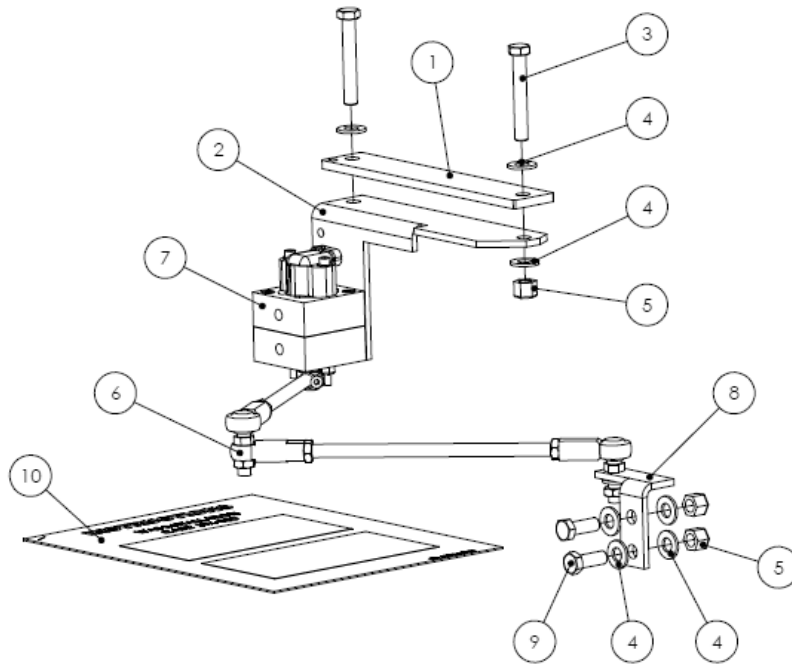

Item	Component	Part Number	Qty
1.	Bracket, WAS Top	202-0163-01	1
2.	Bracket, WAS Bottom	202-0162-02	1
3.	Bolt, 3/8 16 x 2-1/2" Hex GR8 ZP	512-0025-01	2
4.	Washer, Flat 3/8" ZP	516-0001-01	8
5.	Nut, Lock 3/8 - 16 Nylon Insert	518-0001-01	4
6.	Linkage Assembly	200-0255-01	1
7.	Wheel Angle Sensor Assembly	200-0015-01	1
8.	Bracket, Linkage	202-0164-01	1
9.	Bolt, 3/8 16 x 1" Hex GR8 ZP	512-0001-01	2
10.	Instruction Guide	602-0443-01	1

Overview

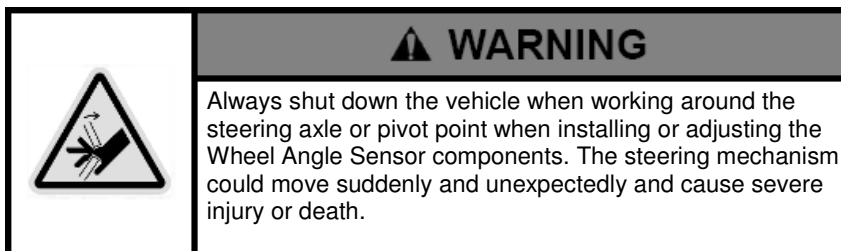

These instructions provide the procedure for installing the Wheel Angle Sensor on the supported vehicles listed. The Wheel Angle Sensor sends feedback to the AutoSteer system to give it the relative position of the steering axle, pivot point, or other steering mechanism so the AutoSteer system can better predict how far and fast to turn.

Note: This installation requires the installer to cut the standard length of rods to specific lengths to work on the vehicle. This manual provides suggested cut lengths and final assembly lengths as a best recommendation. However due to the high possibility of variations to the steering mechanisms it is always the responsibility of the installer to verify the suggested lengths will work for their particular installation. The manufacturer is not responsible for damage caused by incorrectly installed Wheel Angle Sensors. The installer takes responsibility for all risks from damage and injury when installing a Wheel Angle Sensor on a vehicle.

Supported Vehicles

The following models have been confirmed to be compatible with this Wheel Angle Sensor Kit:

Supported Make, Models, and Year Model was First Released	Page
• <i>CaselH STX-375, STX-425, STX-450, STX-500 (2002 -)</i>	3
• <i>New Holland TJ-375, TJ-425, TJ-450, TJ-500 (2002 -)</i>	3

-
- CaseIH STX-375, STX-425, STX-450, STX-500 (2002 -)
 - New Holland TJ-375, TJ-425, TJ-450, TJ-500 (2002 -)
-

Install Wheel Angle Sensor Brackets

The Wheel Angle Sensor needs to be connected to two points on the vehicle's steering mechanism. One point is stationary and the other point moves as the steering mechanism turns from right to left. Follow the procedure to attach the Wheel Angle Sensor Brackets and Wheel Angle Sensor.

Install Wheel Angle Sensor Brackets

1. Locate the Wheel Angle Sensor mounting position on the left side near the articulation point.



2. If the vehicle has a side shield, remove the four bolts holding it in place with a 9/16" socket and ratchet

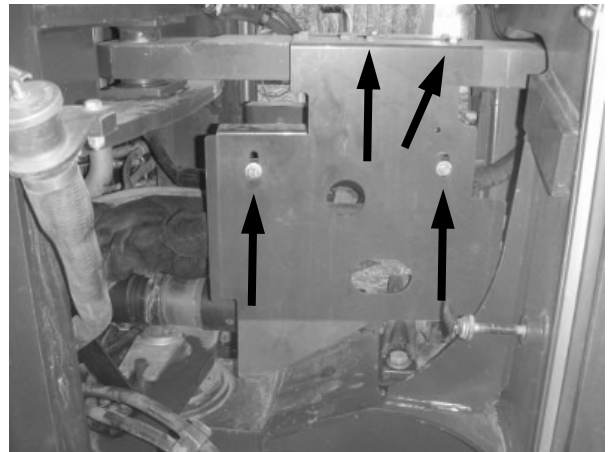

Install Wheel Angle Sensor Brackets

3. The circle on the left on the lower, rear cross beam on the frame shows where the Wheel Angle Sensor Mounting Bracket is attached to.
4. The circle on the right shows where the Linkage Rod Mounting Bracket will be attached to.

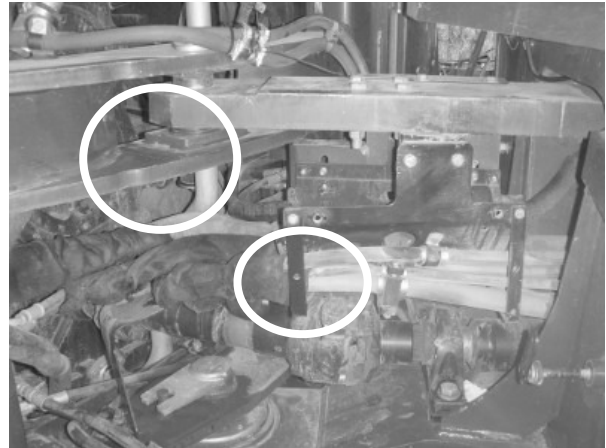

5. Attach the Wheel Angle Sensor to the Wheel Angle Sensor Bottom Bracket with two 3/8" x 5/8" bolts and flat washers.

Note: Verify that the wire connector is facing away from the bracket before attaching the Wheel Angle Sensor to the bracket.

6. Tighten the bolts with a 9/16" ratchet wrench.
7. Loosely attach the Wheel Angle Sensor Top Bracket to the Wheel Angle Sensor Bottom Bracket with two 3/8" x 2-1/2" bolts, flat washers, and nuts.

Note: Do not tighten these at this time.



8. Slide the bracket onto the lower cross beam as shown.
9. Make sure the bracket is parallel with the direction of travel of the vehicle and snug against the outside part of the frame as shown.

Note: The Wheel Angle Sensor should be located towards the front and to the outside of the bracket.

10. When everything is in position, tighten the bracket with a 9/16" wrench and 9/16" socket and ratchet.

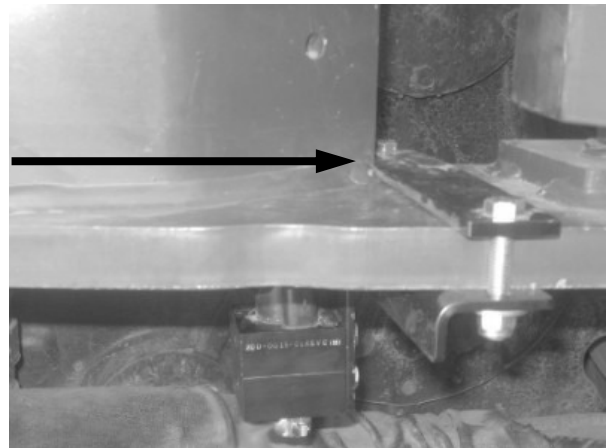

Install Wheel Angle Sensor Brackets

11. Temporarily attach the top hole of the Linkage Rod Mounting Bracket to the outside part of the metal bracket with one of the 3/8" x 1" bolt and 3/8 nut as shown.
12. Tighten the bolt with a 9/16" wrench and 9/16" socket.
13. Use a 3/8" drill bit to drill a hole through the bracket for the bottom hole.

Note: When drilling be careful not to damage any hoses on the back side of the bracket.



14. After drilling the hole, remove the bracket from the outside and then reattach it to the inside of the bracket with two 3/8" x 1" bolts and 3/8" nuts as shown.

Note: The linkage bracket should face the front of the vehicle.

15. Tighten the bracket with a 9/16" wrench and 9/16" socket and ratchet.

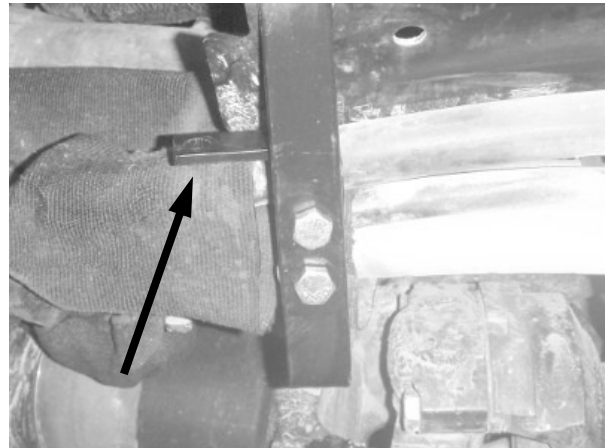

Cut the Wheel Angle Sensor Rods to Length

The Wheel Angle Sensor rods are shipped longer than they need to be. These rods must be cut with a hack saw or other cutting device to the proper length to allow the linkage rods to allow the Wheel Angle Sensor to achieve the maximum number of counts as the steering wheel is turned from full right to full left.

Note: Due to the variability of the possible mounting positions, axle options, and wheel angle stops on the vehicle, it is the responsibility of the installer to verify the suggested lengths provided in this manual are correct for each individual installation prior to cutting the rods. Failure to verify the fit on your specific vehicle may cause damage to the Wheel Angle Sensor components or vehicle when the steering wheel is turned. This damage is not covered by warranty. Always verify the clearances prior to permanently cutting and connecting the Wheel Angle Sensor Rods to the Wheel Angle Sensor Brackets.

Note: Prior to cutting the rods, always mark the rods and temporarily connect them to the Wheel Angle Sensor Brackets. Manually position the steering mechanism at the full left and right positions and verify that if the rods were cut to the suggested lengths, nothing will be damaged. **DO NOT CUT THE RODS UNTIL THE FIT IS VERIFIED.**

Figure 1 shows where to take the measurements for the Wheel Angle Sensor Rod and Linkage Rod. *Table 1* provides the typical rod lengths that work for most installations. Use these values as a starting point and adjust as needed for your specific installation.

Note: Secure the rods in a vice or other device while cutting. Protect the threads so they are not damaged. It is advisable to attach a nut on the side of the metal rod that is going to be kept in order to clean the threads after the cut has been made. Clean the ends of the threaded rods using a file and verify the threads are still good after cutting them.

Figure 1 Wheel Angle Sensor Rod and Linkage Rod Cut Length Measurement Points

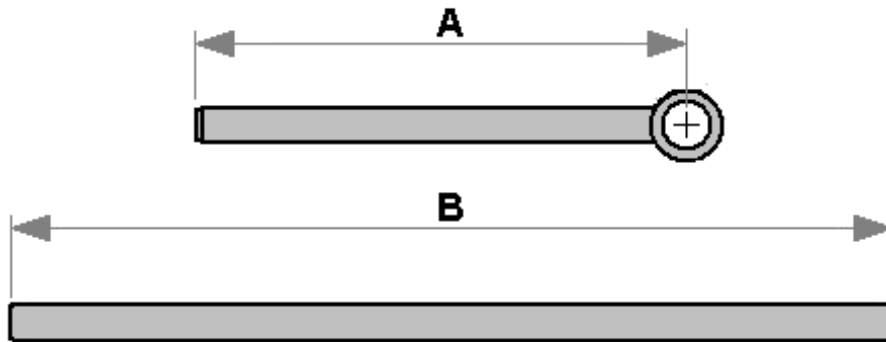

Table 1 Wheel Angle Sensor Rod and Linkage Rod Suggested Cut Lengths

Rod	Length
A	5-1/2 inches (140mm)
B	8-1/2 inches (216mm)

Assemble the Linkage Rod Hardware

After cutting the Linkage Rods to the proper lengths the ball joints and other hardware must be attached and prepared for the installation.

Note: Never connect and turn the steering wheel with the Linkage Rods connected until the fit has been verified.

Assemble the Linkage Rod Hardware

1. Attach a jam nut to the end of the Wheel Angle Sensor Rod (A).
2. Connect the Eye Connector to the end of the Wheel Angle Sensor Rod.

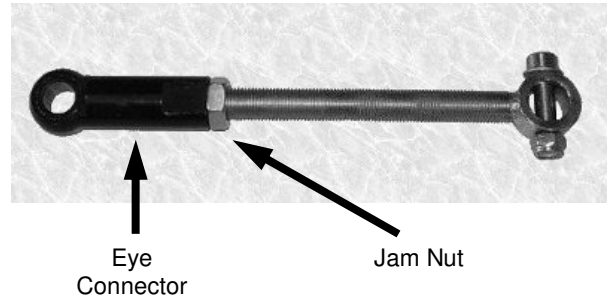

3. Attach a jam nut to each end of the Linkage Rod (B).
4. Attach the ball joints to both ends of the linkage arm.

Note: The bolts for the ball joints should be pointing in the opposite direction as shown.

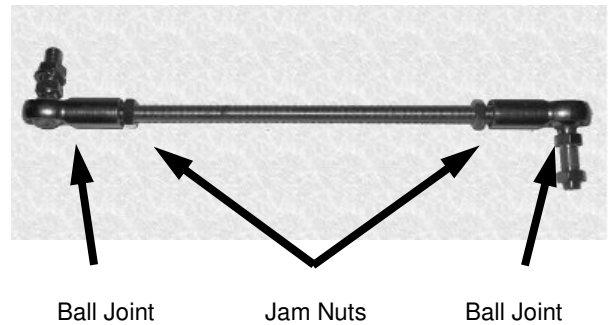

After assembling the Wheel Angle Sensor and Linkage Rods, use *Figure 2* to determine the measurement points and Table 2 for the suggested lengths of the rods for the final assembly.

Note: Always verify that the suggested measurements will work on your installation. These measurements are provided as a starting point only and must be adjusted at the time of the installation to ensure that nothing is damaged when the steering wheel is moved. **DO NOT PERMANENTLY CONNECT THE RODS TOGETHER UNTIL THE FIT IS VERIFIED.**

Figure 2 Wheel Angle Sensor Rod and Linkage Rod Cut Assembled Measurement Points

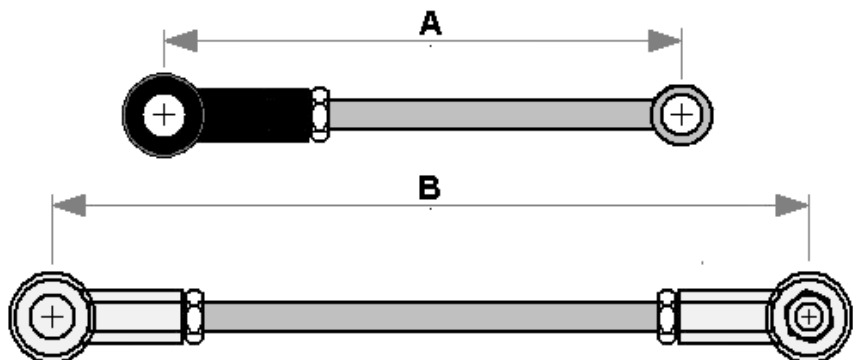

Table 2 Wheel Angle Sensor Rod and Linkage Rod Suggested Assembled Lengths

Rod	Length
A	6-1/2 inches (165mm)
B	10 inches (254mm)

Attach Wheel Angle Sensor and Linkage Rods

The Wheel Angle Sensor Linkage Rod will be attached to the Wheel Angle Sensor and the Linkage Rod will be attached to the Linkage Rod Bracket. Do not attach the Wheel Angle Sensor Rod to the Linkage Rod until the fit has been confirmed and the steering mechanism has been manually checked at the full right and full left positions.

Attach Wheel Angle Sensor and Linkage Rods

1. Attach the Wheel Angle Sensor Rod to the Wheel Angle Sensor with the screw, washer, and lock nut that came with the assembly.
2. The rod will point to the left.

Note: It is important that the flat washer goes on the screw head side and NOT the nut side when attaching the arm.

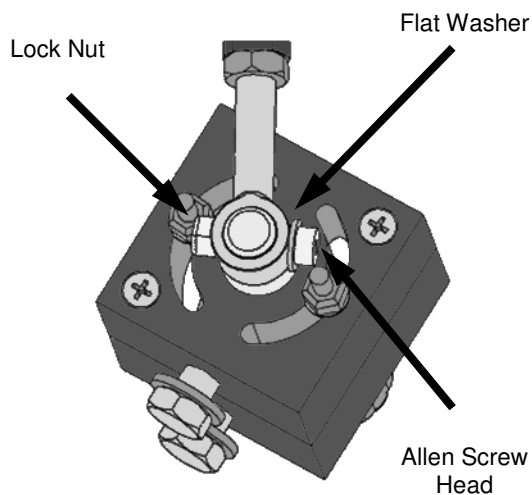

Attach Wheel Angle Sensor and Linkage Rods

- Tighten the screw on the Wheel Angle Sensor shaft with a 1/8" Allen wrench and a 3/8" open end wrench.

Note: The screws holding the potentiometer sensor to the top of the metal block should stick out from the bottom of the Wheel Angle Sensor assembly (shown by arrows). The Allen head should always be on the top of the sensor.

The screws stick out on the bottom to prevent the sensor from being accidentally over extended by hand. Verify these screws are installed correctly and the Wheel Angle Sensor Rod moves back and forth freely between the two screws at the bottom of the Wheel Angle Sensor block.

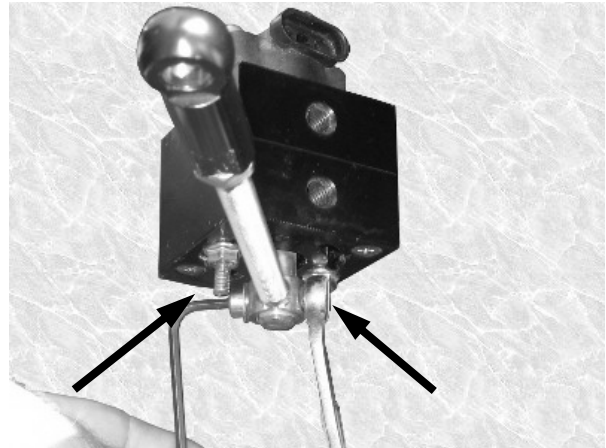

- Attach the linkage rod to the linkage bracket. The bolt attaches to the top of the bracket and the nut and lock washer go on the bottom.
- Tighten the ball joint to the bracket with a 1/2" and 9/16" open end wrenches.

Note: Do not attach the Wheel Angle Sensor Rod to the Linkage Rod at this time. Make sure they are disconnected until after the maximum right and maximum left stops have been verified not to damage the assembly.

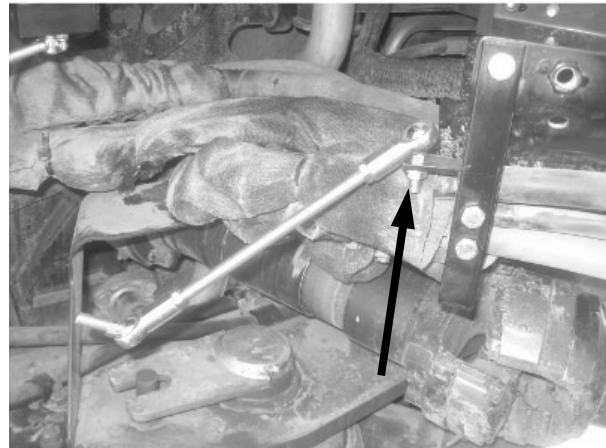

- With the linkage rods disconnected, start the vehicle and manually turn the steering wheel so that the vehicle will travel straight ahead when moving.
- Temporarily attach the Wheel Angle Sensor Rod and Linkage Rod together.
- Rotate the Wheel Angle Sensor potentiometer on top of the mounting block so that the plastic wire connector is parallel to the Wheel Angle Sensor Rod.
- After the potentiometer has been adjusted, tighten the potentiometer screws with a 3/8" wrench and 5/32" Allen wrench.

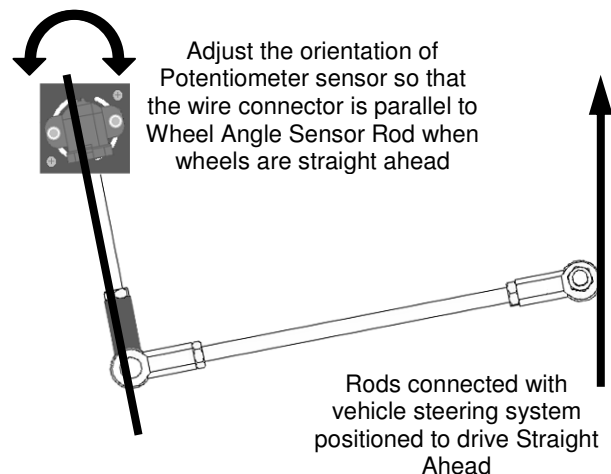

Attach Wheel Angle Sensor and Linkage Rods

10. Disconnect the linkage rods and then turn the steering wheel manually so the steering mechanism is turned to the full left position.

Note: The vehicle may need to be driven a short distance in order to get the steering system to move to the full left position.

11. Reattach the linkage assembly and verify that the sensor and linkage rods will not be damaged. Adjust the rod lengths as necessary.



12. Disconnect the linkage rods and turn the steering wheel manually so the steering wheels are turned to the full right position.

Note: The vehicle may need to be driven a short distance in order to get the steering system to move to the full right position.

13. Reattach the linkage assembly and verify that the sensor and linkage rods will not be damaged. Adjust the rod lengths as necessary.



14. Repeat *Step 6* through *Step 13* until the rod lengths have been adjusted and the potentiometer is centered to get the maximum sensor movement.

15. The maximum movement is reached when the Wheel Angle Sensor Rod will sweep from approximately 3/16" (5mm) from both bolt heads when the steering mechanism is turned to the maximum right and left positions.

Note: An Ohm meter can also be used to determine if there is enough sensor movement. Connect the Ohm meter to pins A and B of the Wheel Angle Sensor. Measure the Ohm reading at the maximum left and right position. After subtracting the smaller number from the larger number, there should be at least a 3.5 Kilo-Ohms change. The reading should also never go below 1.5 or higher than 6.1 Kilo-Ohms as this is reaching the limits of the potentiometer and could damage the sensor.

Potentiometer Screw Stops

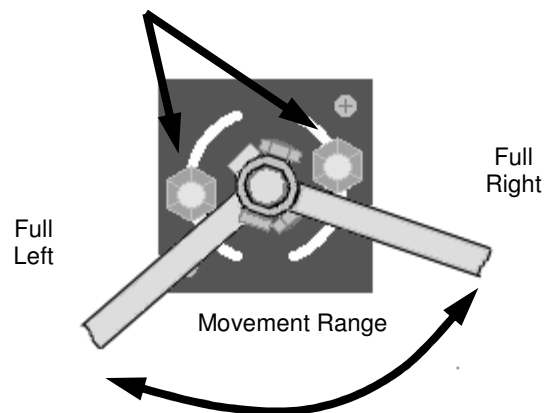

Wheel Angle Sensor as Seen from the Bottom

Attach Wheel Angle Sensor and Linkage Rods

- 16.** Once all the adjustments are complete, tighten all lock nuts and bolts on the Linkage and Wheel Angle Sensor Rods. A 1/2" and two 9/16" wrenches are required to tighten all the connections.
- 17.** Reattach the side shield if it was removed earlier.

